

# ONE PIECE CHECK VALVE

1/4" & 1/2" NPT  
0 - 3000 Psig

### Description

Compact one piece body, fully retained O'ring seal, poppet type check valve. Available in 1/4" and 1/2" NPT in brass or 316 stainless steel. Suitable for working pressures to 3000 Psig. A wide selection of seal materials and crack pressures make the Series OPC a quality and cost effective solution. All valves are 100% factory tested and available cleaned and packaged for oxygen service.

### Features and Benefits

- Compact One Piece Body Construction
- Working Pressures to 3000 Psig (206 bar)
- Full Back Pressure Rating
- Fully Retained O'Ring Seal
- Cracking Pressures from .3 to 25 Psig (0.02 - 1.7 bar)
- 100% Factory tested for crack, leakage and reseal performance

### Technical Data

- Nominal Crack Pressures: .3, 1, 10, & 25 Psig (0.02, 0.07, 0.7 & 1.7 bar)
- Maximum Pressure: 3000 Psig @ 70°F (206 bar @ 21°C)
- Temperature Rating:  
-80°F to 450°F (-62°C to 232°C)

*(based on seal selection, see ordering information)*

### Materials of Construction

Component	Valve Body Material	
	Brass	Stainless Steel
Body, Poppet, Seat Insert, Locking Screw <sup>1</sup>	Brass, ASTM B16	316 SS, ASTM A479 <sup>2</sup>
Spring	302 SS, ASTM A313	
O'Ring Seal <sup>3</sup>	Buna-N	Viton™

<sup>1</sup> 1/4" Brass valves have 316 SS locking screw

<sup>2</sup> PTFE dry lubricant applied to threads

<sup>3</sup> Lubricated with Krytox™ GPL-202



# SERIES OPC ONE PIECE CHECK VALVE

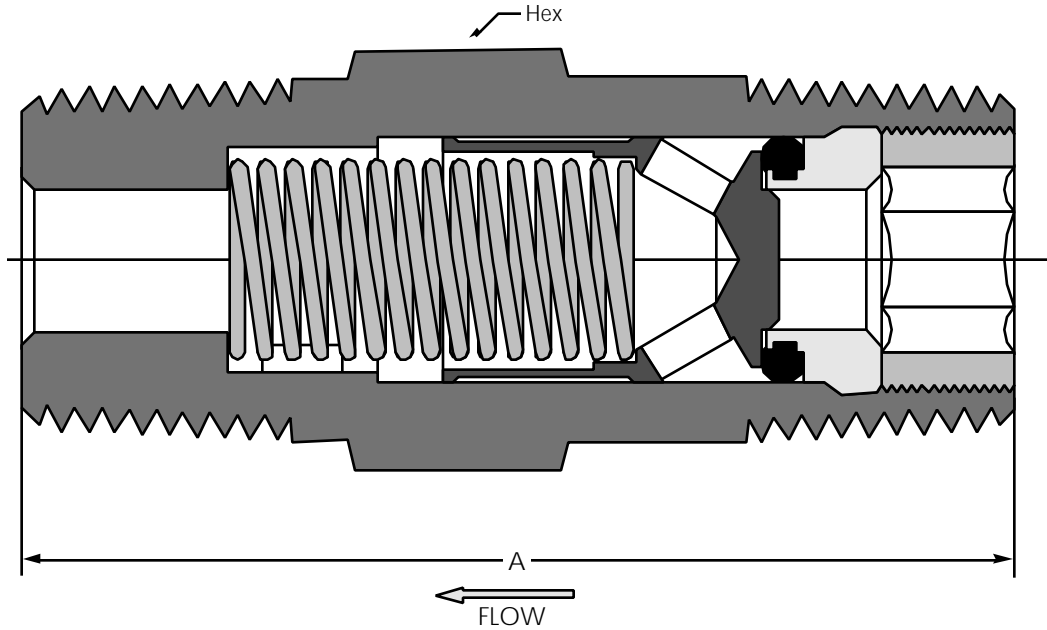

## Dimensional/Flow Data

Model Code	Port Configuration		A(inches)	Hex	Cv
	Inlet	Outlet			
OPC-4P	1/4" Male NPT	1/4" Male NPT	1.62	9/16"	0.35
OPC-4MF	1/4" Male NPT	1/4" Female NPT	1.75	3/4"	
OPC-4FF	1/4" Female NPT	1/4" Female NPT	2.41		
OPC-8P	1/2" Male NPT	1/2" Male NPT	2.28	7/8"	1.20
OPC-8MF	1/2" Male NPT	1/2" Female NPT	2.83	1 - 1/16"	

Flow tested in accordance with ISA S75.21 with air. Restrictions in the inlet or outlet piping may reduce flow.

## Ordering Information

**OPC - 4P SS - V - 1**

**SERIES** \_\_\_\_\_  
OPC - One Piece Check Valve

**PORT CONFIGURATION** \_\_\_\_\_  
4P - 1/4" Male x 1/4" Male  
4MF - 1/4" Male x 1/4" Female  
4FF - 1/4" Female x 1/4" Female  
8P - 1/2" Male x 1/2" Male  
8MF - 1/2" Male x 1/2" Female  
NPT Threads per ANSI/ASME B1.20.1

**MATERIAL CODE** \_\_\_\_\_  
B - Brass  
SS - 316 SS

**CRACK PRESSURE**  
.3 - (.1 - .4 Psig) (0.02 bar)  
1 - (.5 - 1 Psig) (0.07 bar)  
10 - (8 - 12 Psig) (0.7 bar)  
25 - (22 - 27 Psig) (1.7 bar)

**SEAL MATERIAL**  
V - Viton™, -10°F to 375°F (-23°C to 190°C)  
B - Buna-N, -40°F to 250°F (-40°C to 121°C)  
N - Neoprene, -40°F to 300°F (-40°C to 148°C)  
EP - Ethylene Propylene, -65°F to 300°F (-54°C to 148°C)  
FS - Fluorosilicone, -80°F to 350°F (-62°C to 176°C)  
S - Silicone, -70°F to 450°F (-56°C to 232°C)  
T - TFE, -50°F to 350°F (-46°C to 177°C)  
TFE Seal may require back pressure to seal leak-tite

**OPTIONS**  
Oxygen cleaning, alternative seals and other thread configurations, consult factory  
Viton, Krytox -™ DuPont

PROPER COMPONENT SELECTION - When specifying a component, the total system design must be considered to ensure safe and trouble-free performance. Intended component function, materials compatibility, pressure ratings, installation, environment and maintenance are the responsibility of the system designer.



[www.generant.com](http://www.generant.com)

SA.SL.OPC002.A.0416

**1865 Route 23 South PO Box 768 Butler, New Jersey 07405 973.838.6500 Fax 973.838.4888**